

be.pure

KATARA

WITH UNDER-TABLE BOX



INSTRUCTION MANUAL



General information



Intended use

This product is intended for domestic use and similar applications, such as:

- kitchen areas for staff in shops, offices and other professional areas;
- farms and customers in hotels, motels and other residential environments;
- bed and breakfasts;
- catering services and similar non-retail applications;
- public areas in a supervised environment.

Device for indoor use only.

Keep the device away from water jets and heat sources.

Installation

- Before installation, have the device cleaned by a qualified technician.
- During installation, ensure that the device is not standing on the power cable.
- Install and level the appliance on a stable surface and choose a room that is suitable for its dimensions and the intended use.
- Ensure that the product is not located near any heat sources.
- Leave sufficient space (at least 10 cm) around the appliance to ensure adequate ventilation.
- Place the device in a clean, dry and well-ventilated room.
- The device is designed for rooms with a temperature ranging between 5 °C and 32 °C – climate class N. The installation site must be clean, dry, well ventilated and have a temperature ranging between 16 °C (61 °F) and 32 °C (90 °F).
- The installation surface must be level and have sufficient load-bearing capacity for the weight of the product.
- To ensure adequate ventilation, leave at least 10 cm of space around the appliance.
- Do not place any other electrical appliances in the immediate vicinity of the water dispenser.
- Connect the device to a water supply that provides only drinking water or comes from ENYA.
- Keep the areas around the appliance dry to prevent people from slipping on wet surfaces.

Electrical connection

- It must be possible to switch off the electrical power supply either by unplugging the appliance or by means of a bipolar mains switch with a break contact distance above the socket outlet that allows complete disconnection in the event of a category III overvoltage.
- Check that the voltage specified on the type plate corresponds to that at the installation site.
- The appliance must be protected by an earth leakage circuit breaker.
- If the power cable is damaged, it must be replaced by the manufacturer or a qualified technician.
- Do not use extension cables or multiple adapters.
- The product may only be powered using the device supplied.
- The supply voltage and frequency must correspond to the values on the type plate.
- The device must be protected by a residual current device.
- The power cable must be laid so that it is not crushed, pinched, stretched, stepped on, bent, wet or obstructed.

KATARA WITH UNDER-TABLE BOX

- Do not use extension cables or adapters.
- The installation must be carried out in accordance with local hydraulic regulations.
- The connections to the water supply system and the devices connected to the mains must be dimensioned, installed and maintained in accordance with the regulations applicable at the installation site.
- The system for interrupting the power supply (by pulling the plug or a two-pole mains switch) must ensure an effective contact opening distance even in the event of a category III overvoltage.
- The cable must be replaced immediately by an authorised technician if it is damaged.

Operation

- The device must not be cleaned with a water jet.
- Do not place any other electrical appliances near the water dispenser.
- Close the main water tap if the device is not going to be used for a long period of time.
- Keep the surrounding areas around the machine dry to prevent slipping hazards due to wet spots.

Safety and user instructions

- This appliance can be used by individuals (including children at the age of 8 or older) with reduced physical, sensory or mental capabilities, or lack of experience and knowledge, provided they are supervised or instructed in the use of the appliance by a person responsible for their safety.
- Children must be supervised. Ensure that the device is not played with.
- The device may only be installed in areas that can be supervised by qualified personnel.

Maintenance and cleaning

- Before carrying out any maintenance or cleaning work, the power plug must be disconnected or the power supply interrupted.
- Disconnect the device from the mains before cleaning or maintenance.
- Cleaning and maintenance must not be carried out by children.
- Disconnect the water supply if the appliance is not going to be used for a long period of time.

Hydraulic regulations

- This appliance must be installed in accordance with local hydraulic standards.
- The connections and devices for hydraulic hoses or pipes that are connected directly to a drinking water network must comply with federal, state and local regulations in terms of their dimensions, installation and maintenance.

Table of contents

KATARA

1	Recommendations for environmental protection	6
1.1	Packaging	6
1.2	Disposal	6
2	The device	7
2.1	Front view	7
2.2	Bottom view	8
3	Keyboard description	9
4	Dosing keyboard specifications	10
5	Description of the keypad – Model HOT	11
6	Technical features	12
6.1	Technical data table	13
7	Installation	13
7.1	Setting up the device	13
7.2	Connection to the under-table box	14
7.3	Electrical connection	15

Table of contents

UNDER-TABLE BOX

1	Introduction	16
1.1	General information	16
1.2	Symbols used	16
2	Safety	17
2.1	General safety regulations	17
2.2	Installation instructions	17
2.3	Intended use	17
2.4	Safety pictograms	18
2.5	Personal protective equipment	18
3	The under-table box	19
3.1	Versions	19
3.2	Front	19
3.3	Rear	20
3.4	Technical features	21
4	Installation	22
4.1	Preparing the installation area	22
4.2	Unpacking	22
4.3	Installation	22
4.4	Under-table box for KATARA	23
4.5	Supplies	24
4.6	Cold water temperature control	29
4.7	Regulating the flow of carbonated water	29
4.8	Hot water temperature control (mod. HOT)	30
4.9	Replacing the CO ₂ bottle	30

1 Recommendations for environmental protection

1.1 Packaging

The packaging material is 100% recyclable. Observe local regulations for disposal. Keep the packaging material out of the reach of children, as it may pose a potential hazard.

1.2 Disposal

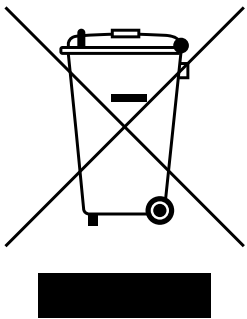

The product is made from recyclable materials.

This device has the conformity marking in accordance with European Directive 2012/19/EU on waste electrical and electronic equipment (WEEE). If the device is disposed of correctly by the user, there is no risk to the environment or health. The symbol on the device indicates that this device should not be treated as household waste, but should be taken to special collection and recycling points for waste electrical and electronic equipment. Cut the power cable before disposal.

For further information on the treatment, recovery and recycling of this product, please contact your local authority, waste collection point or the retailer where you purchased the product.

KATARA WITH UNDER-TABLE BOX

2 The device

2.1 Front view



- 1 Button for chilled sparkling water
- 2 Button for chilled water
- 3 Water dispenser
- 4 Button for programming dosages – Portion Control
(only for models where the programmed water dispenser has been ordered)

KATARA WITH UNDER-TABLE BOX

2.2 Bottom view

Electrical box

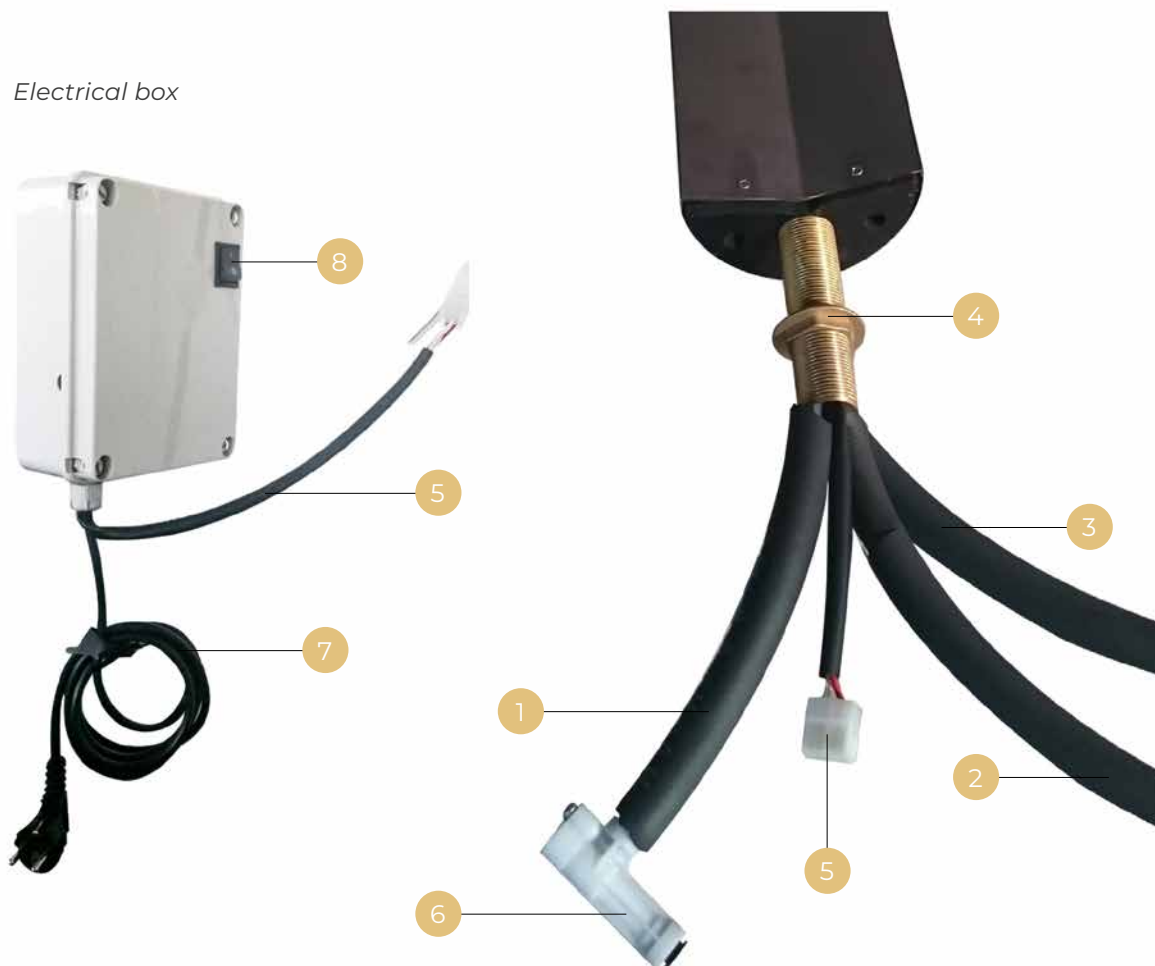

1 Sparkling water inlet hose Ø8mm

2 Inlet hose for cooled water Ø8mm

3 Inlet hose for uncooled still water (mod. 3 buttons) or hot water (mod. HOT) Ø8mm

4 Retaining ring 1"

5 Connection cable

6 Compensator

7 Power supply cable

8 Main switch

3 Keyboard description

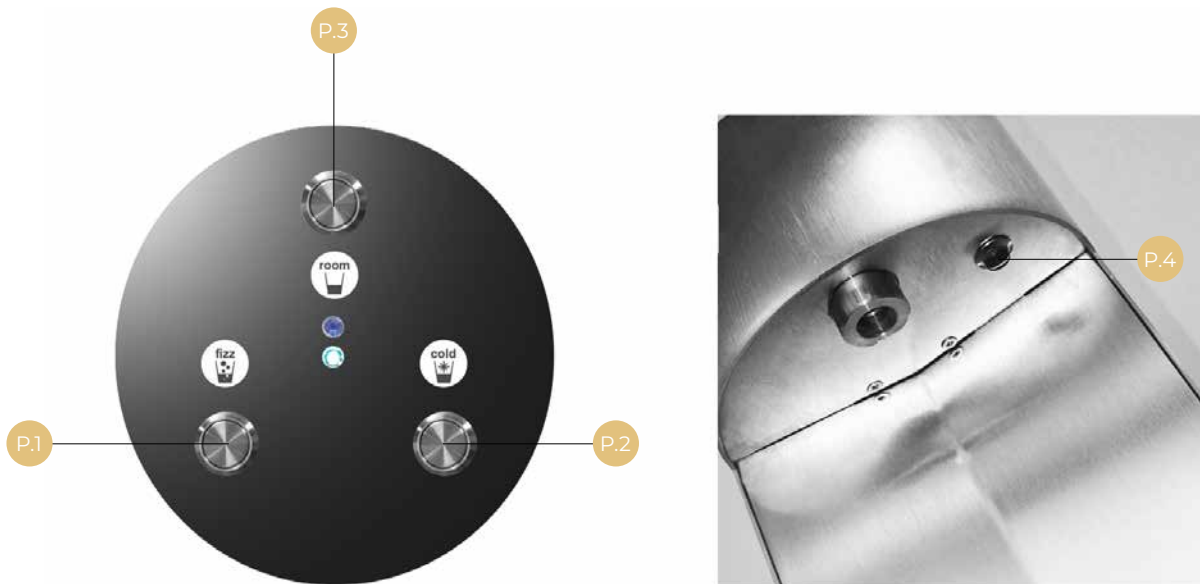

- P.1 Button for chilled sparkling water
- P.2 Button for chilled water
- P.3 Button for unchilled still water (mod. 3 buttons)
- P.4 SET UP button

On models without programmed water dispensing, dispensing only works by holding down the dispensing button.

4 Dosing keyboard specifications

If you have ordered a KATARA with portion control, the dispensing dosage can be easily programmed during installation.

Key functions:

- Water dispensing button SPARKLING WATER (P.1)
- Water dispensing button CHILLED WATER (P.2)
- Water dispensing button UNCHILLED STILL WATER (P.3)

Press the button for 1 second for a small serving (one glass, 200 cc), press the button for longer than 3 seconds for a large serving (1 litre). The water flow is automatically regulated and stops when the desired amount is reached, or can be interrupted at any time by pressing the button again.

The dosing system is not available for HOT versions.

Programming the dosages

The programmable dosing card can be used to set the 2 buttons as desired. The programming mode is activated by pressing and holding (> 4 seconds) the button combination P.2 + P.4 (chilled water button + SET UP button) for 2-button models or P.3 + P.4 (unchilled still water button + SET UP button) for 3-button models. The start of the programming phase is confirmed by a triple beep. During this phase, LEDs L.1 and L.2 flash.

To set the maximum dispensing limit for all buttons, press the respective dispensing button (for 1 second for a small dispensing quantity, for more than 3 seconds for a large dispensing quantity) and then again once the desired quantity has been reached.

Programming mode is activated by pressing and holding (> 4 seconds) the key combination P.2 + P.4 (chilled water button + SET UP button) for 2-button models or P.3 + P.4 (unchilled still water button + SET UP button) for 3-button models, and the new data is saved. The maximum dosage that can be set for each button is 65 seconds, i.e. approximately 3 litres.

5 Description of the keypad – Model HOT

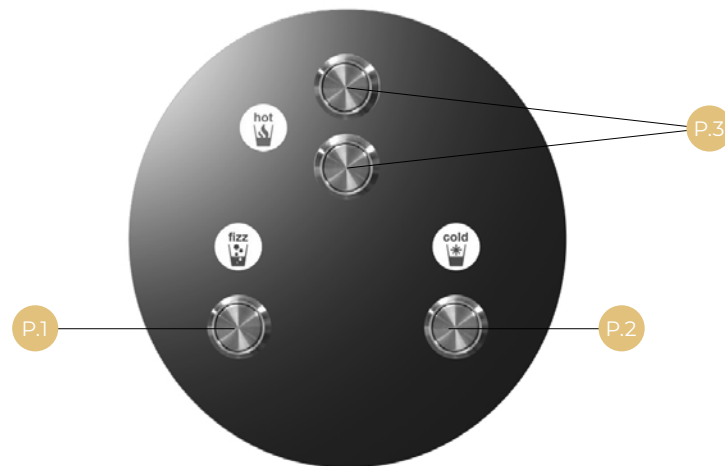

- P.1 Button for chilled sparkling water
- P.2 Button for chilled water
- P.3 Button for hot water

Dispensing only works when the dispensing button is held down.
The dosing system is not available for HOT versions.

For safety reasons, you must press and hold both hot water buttons simultaneously to dispense hot water.

6 Technical features

Dimensions (mm)

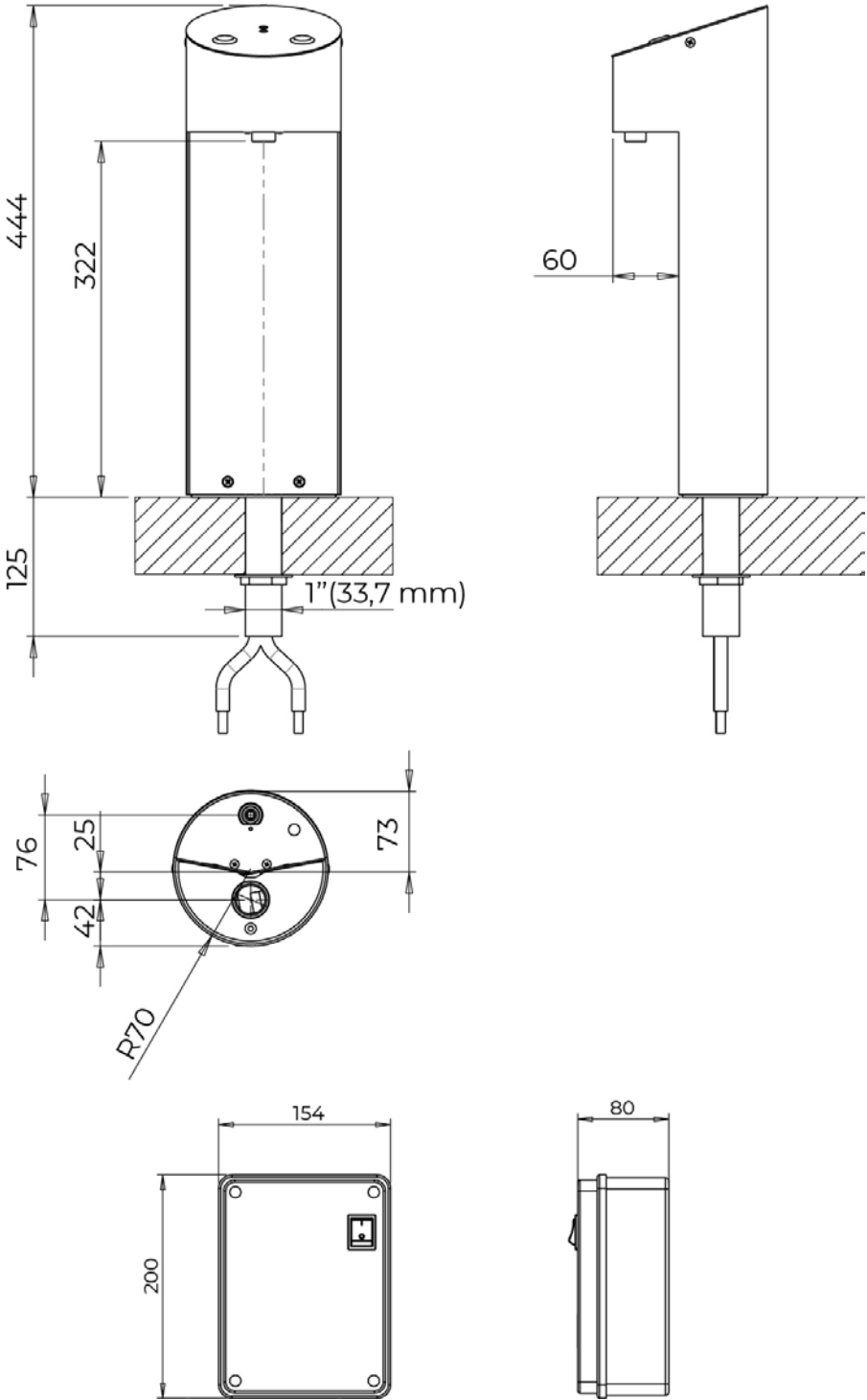

6.1 Technical data table

	KATARA (mod. 2 buttons)	KATARA (mod. 3 buttons)
Power supply	230 V – 50 Hz	230 V – 50 Hz
Power consumption	27W – 0.18A	35W – 0.15A
Water inlet hose connection	JG Ø 8mm	JG Ø 8mm
Height of water dispenser (mm)	322	322
Dimensions (mm)	Ø 140 x 574	Ø 140 x 574
Dimensions of electrical box LxWxH (mm)	154x80x200	154x80x200
Packaging dimensions LxWxH (mm)	710x180x180	710x180x180
Net weight (kg)	8	8
Gross weight (kg)	9	9

For the technical data sheet of other models, see the technical data sticker on this device.

7 Installation

7.1 Setting up the device

- Gloves must be worn when setting up the device.
- The device must be positioned or adjusted by two people at the same time.
- The device must be installed far away from heat sources.
- Only set up on level surfaces.

- Drill a 35 mm diameter hole in the selected surface.
- Pull the inlet hoses of the electronic tap through the hole and secure the unit to the surface using the 1" retaining ring supplied.
- Open the cover of the electrical box. Ensure that the plug is not connected and use the screws to attach the box to the wall under the tap at a distance of max. 55 cm.
- **CAUTION:** When installing the device, ensure that the power cord is not pinched or damaged.

KATARA WITH UNDER-TABLE BOX

7.2 Connection to the under-table box

This electronic tap (= KATARA) must be connected to an under-table box. Do not connect the box directly to the water supply.

Connect the inlet hoses to the under-table box (external diameter 8 mm). Pay attention to the labels on the hoses (*fig. 1*).

For the HOT model, use food-grade hoses and connectors made of PTFE or equivalent material that are suitable for high temperatures (100 °C). Do not connect the electronic tap to cooling units that dispense water at temperatures above 100 °C.

Once the hoses are connected, the tap can be opened. Check that there are no leaks.

The screw on the compensator **1** can be used to regulate the water flow for the sparkling water dispenser: turn clockwise to reduce and anticlockwise to increase the water flow.

Before drinking water from the system, flush the water line sufficiently by drawing water from each dispensing point.

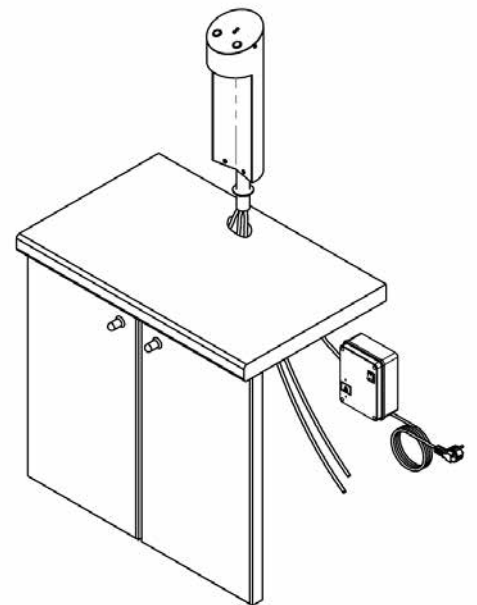

Fig. 1



Fig. 2

KATARA WITH UNDER-TABLE BOX



Fig. 3



Fig. 4

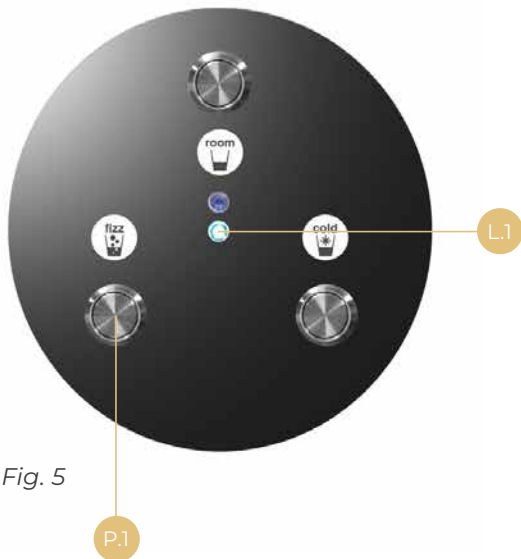

Fig. 5

7.3 Electrical connection

The connections must comply with local standards. The device must be earthed in accordance with legal requirements.

Connect the tap to the electrical box (2) using the appropriate cable (1), plug the power supply connector (3) into the wall socket and press the main switch (4) to "I". The electronic tap is now activated and the POWER ON LED (L1) is lit.

Position the socket so that the device can be disconnected from the mains after installation.

Press the "sparkling water" button (P1) to release any air in the circuit. This allows the connected cooler pump of the built-in appliance to feed water into the carbonator.

DO NOT use solvent- or alcohol-based products or high acidic products that could damage the stainless steel surface.

1 Introduction

1.1 General information

This manual describes the correct installation procedures for the under-table box for the KATARA water dispenser. It contains safety instructions and information for installation by a qualified installer and electrician. The descriptions and illustrations contained in this publication are not binding. The manufacturer reserves the right to make any changes it deems necessary without being obliged to update this documentation.

1.2 Symbols used

Symbols have been used in the manual to highlight text that provides useful information on how to avoid dangerous situations for personnel installing the products and on residual risks. They are also used to highlight general comments that may be of significant importance. The following symbols are used:

**NOTE**

Precedes specific procedures. Failure to comply may result in damage to the installer or maintenance technician.

**CAUTION**

It precedes certain procedures. Failure to observe this may result in damage to the product.

2 Safety

2.1 General safety regulations



- Installation must only be carried out by qualified and authorised technicians.
- Disconnect the appliance from the power supply before any maintenance or cleaning.
- Disconnect the water supply if the device is not going to be used for a long period of time.
- Do not damage the coolant circuit, as it contains highly flammable gas R600 or R290.
- The product must not be cleaned with a water jet.
- Keep the areas around the appliance dry to prevent people from slipping on wet surfaces.

2.2 Installation instructions



- Only connect the product to water pipes that supply drinking water.
- The product must be disinfected by an authorised technician before each installation.
- The product contains flammable refrigerant gas.
- Install the product away from heat sources.
- Install the CO₂ cylinder away from heat sources.
- The power cord must be laid out so that it is not crushed, pinched, stretched, stepped on, bent, wet or obstructed. Do not use extension cords or adapters.
- Work on the electrical system may only be carried out by a qualified electrician.
- Disinfection work may only be carried out by a qualified installer.
- The supply voltage and frequency must match the values on the type plate.
- Install the product according to the instructions to avoid hazards due to instability.



- The load-bearing capacity of the installation surface must be suitable for the weight of the product.
- Leave at least 10 cm of space around the product to ensure adequate ventilation.
- Do not place any other electrical appliances in the immediate vicinity of the product.



2.3 Intended use

The products are intended for use as dispensers of chilled drinking water in private, professional households or public institutions (public areas in a monitored environment).

The products must be installed in a clean, dry and well-ventilated room with a temperature between 16 °C (61 °F) and 32 °C (90 °F).

2.4 Safety pictograms

The following safety pictograms are displayed on the product:

Symbol	Meaning	Position
	Read the manual	Main switch or supply tray
	Flammable material	Near the compressor

2.5 Personal protective equipment





Depending on the tasks to be performed, it is essential to use the following personal protective equipment:

Symbol	Meaning	Activity
	Safety shoes	For every activity
	Impact- and cut-resistant protective gloves	Handling loads
	Cut-resistant protective gloves Safety goggles	Use of cutting tools
	Nitrile gloves and safety goggles Face mask with activated carbon filter	Handling chemical and potentially hazardous substances

3 The under-table box

3.1 Versions

The products are available in the following versions:

Versions	ambient 	hot 	cold 	fizz 
Box 30	•		•	
Box 30 FIZZ	•		•	•
Box 30 HOT	•	•	•	
Box 30 HOT FIZZ		•	•	•

3.2 Front

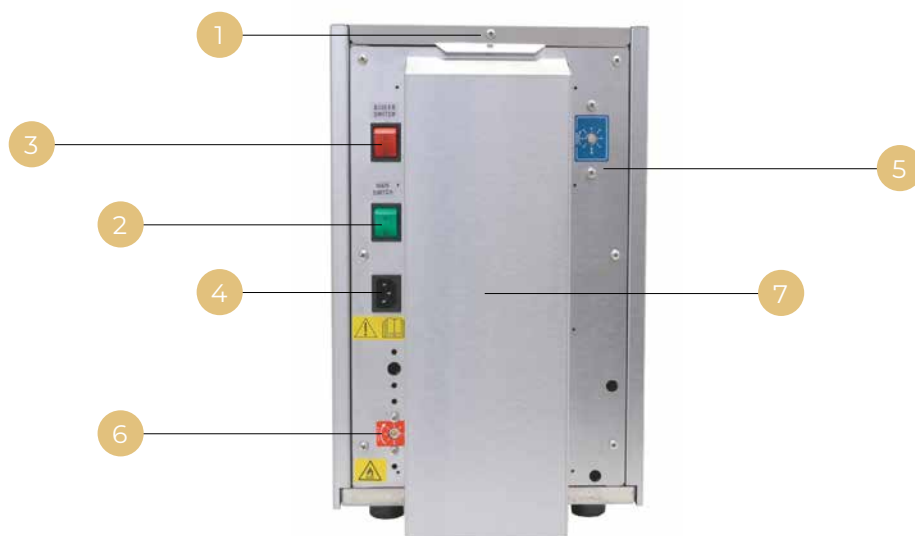

- 1 Fastening screw for the top cover
- 2 Main switch
- 3 Boiler switch (mod. HOT)
- 4 IEC socket for power supply
- 5 Adjustable radiator thermostat
- 6 Adjustable boiler thermostat (mod. HOT)
- 7 Ventilation duct

KATARA WITH UNDER-TABLE BOX

3.3 Rear

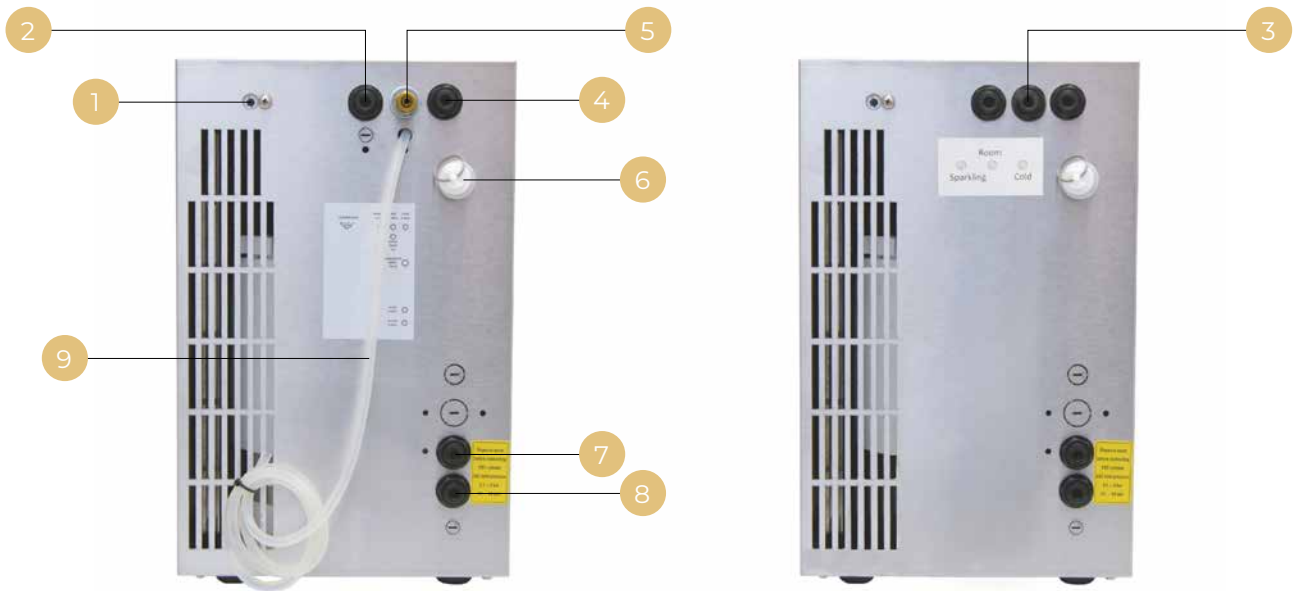

- 1 Compensator
- 2 Connection for carbonated water outlet (mod. FIZZ)
- 3 Connection for room temperature water outlet
- 4 Connection for cold water outlet
- 5 Connection for hot water outlet (mod. HOT)
- 6 Safety valve
- 7 Drinking water inlet connection
- 8 CO₂ inlet connection (mod. FIZZ)
- 9 Condensate drain pipe boiler (mod. HOT)

3.4 Technical features

Versions	Box 30	Box 30 FIZZ	Box 30 HOT	Box 30 HOT FIZZ
Dimensions W x H x D	260 x 416 x 416 mm			
Packaging W x H x D	350 x 510 x 580 mm			
Net weight	21 kg	25 kg	24 kg	26 kg
Gross weight (including packaging)	23 kg	27 kg	28 kg	30 kg
Operating ambient temperature	Min. 16 °C (61 °F) – Max. 32 °C (90 °F)			
Cold water temperature	5 °C (41 °F) – 12 °C (54 °F)*			
Cooling capacity	30 l/h			
Cooling technology	Dry Cooling			
Supply voltage	230 V			
Supply frequency	50 Hz			
Nominal compressor power	1/8 PS			
Type of refrigerant gas	R290			
Water pressure at inlet	2.0 bar (0.2 MPa) – 3.5 bar (0.35 MPa)			
CO ₂ pressure at inlet (if available)	3.5 bar (0.35 MPa) – 4 bar (0.4 MPa)			
Max. absorption	200 W / 1.1 A	280 W / 1.5 A	/	/

* Measured in an environment with a temperature of 25 °C (77 °F) and a water inlet temperature of 20 °C (68 °F).

4 Installation

4.1 Preparing the installation area



The product is not intended for outdoor installation.



If the product has been transported in a horizontal or tilted position, you must wait at least 8 hours before putting it into operation so that the cooling circuit is fully functional.

The installation site must have the following:

- A rigid, horizontal, level floor/surface;
- Convenient connection to the water supply network at the installation site;
- A socket for power distribution;
- Sufficient lighting (min. 300 lx).

4.2 Unpacking

To unpack the product, proceed as follows:

- Cut the strapping bands;
- Lift the box;
- Remove the protective packaging;
- Visually inspect the product to ensure that it is not damaged; Any damage must be reported to the retailer as soon as possible from the date of delivery of the product.

Packaging materials

The packaging materials are fully recyclable. Please observe local regulations when disposing of them. The packaging material must be kept out of the reach of children as it is a potential source of danger.

4.3 Installation



- When setting up the product, ensure that the power cord is not pinched or damaged.
- The product contains flammable refrigerant gas.
- Install the product away from heat sources and water jets.
- Install the product according to the instructions to avoid hazards due to instability.



- Ensure that the location where the product is to be installed is suitable for its weight and is in an environment appropriate for its size and use (see "3.4 Technical features" on page 21).
- Do not place any other electrical appliances in the immediate vicinity of the water dispenser.

4.4 Under-table box for KATARA

The product must be lifted by two people.

Wear work gloves to move the product.

The installation site must ensure the following:

- A horizontal, level surface with sufficient load-bearing capacity to support the weight of the product;
- At least 10 cm around the product to promote ventilation; check if the ventilation grille **1**, if present, is blocked;
- A hole measuring 37 x 130 mm must be made at the base of the surface selected for installation to allow hot air to escape through the ventilation duct **2**;

Ensure that the ventilation duct **2** is located at the hole.

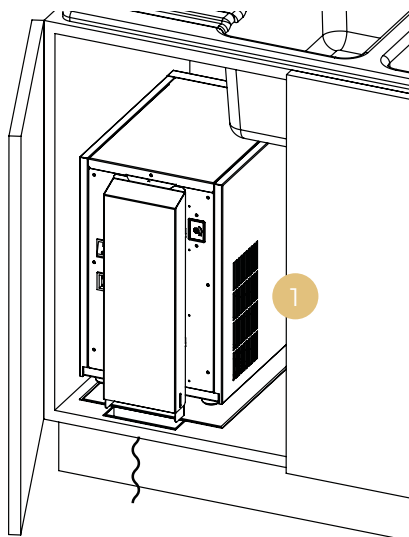
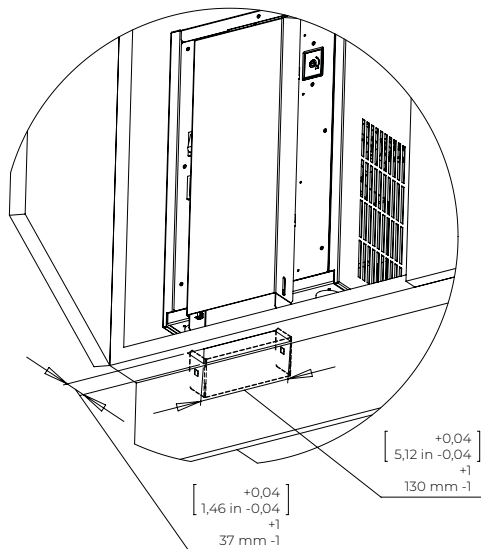

KATARA WITH UNDER-TABLE BOX

If it is not possible to drill the contact surface, remove the ventilation duct 2 by following the instructions:

- Open the top cover: loosen the screw 3 and remove the cover;
- Remove the lower support screws 4;
- Lift the ventilation duct 2 and remove it;
- Ensure that there is still 10 cm of space around the product.



4.5 Supplies

Water connection



- Connect the product to a water supply network.



- The installation must be carried out in accordance with local hydraulic regulations.
- The connections of the water supply system and the devices connected to the mains must be dimensioned, installed and maintained in accordance with the regulations applicable at the installation site.
- Use a new set of connections (fittings, seals, pipes) for the connection to the water supply network.
- Ensure that the pressure of the water entering the product is between 2.0 bar and 3.5 bar.
- If the pressure is greater than 3.5 bar, install a pressure reducer.
- If the water smells strongly of chlorine, install a filter system.
- To reduce the risk of flooding, it is recommended that you install a flood protection valve.

The following components are required for connection to the water supply:

- Food-safe water hoses of suitable length;
- Food-safe CO₂ hose of suitable length;

KATARA WITH UNDER-TABLE BOX

- Connect the water inlet hose to the drinking water connection 5 on the back of the product.



Connecting the taps

Follow the instructions to connect the water supply from the box to the tap (use only food-grade water pipes):

- Connect the hose to the carbonated water outlet connection 6 of the box (mod. FIZZ only) and to the carbonated water inlet connection of the tap;
- Connect the hose to the room temperature water outlet connection 7 of the box and to the room temperature water inlet connection of the tap;
- Connect the hose to the cold water outlet connection 8 of the box and to the cold water inlet connection of the tap;
- Connect the hose to the hot water outlet connection 9 of the box (mod. HOT only) and to the warm water outlet connection of the tap;
- The pipes connecting the box to the tap must be thermally insulated along their entire length.

The under-table box for KATARA is equipped with a safety valve.

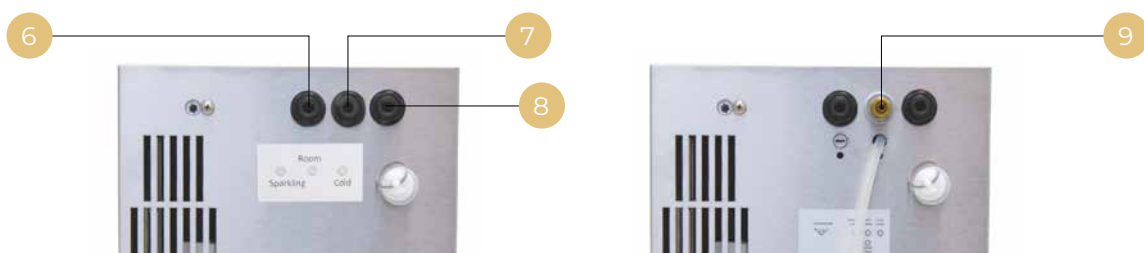

KATARA WITH UNDER-TABLE BOX

Drain connection (mod. HOT)

- Connect the boiler's condensate drain pipe 10 with a drain pipe or plug it into a collection tank (mod. HOT only).

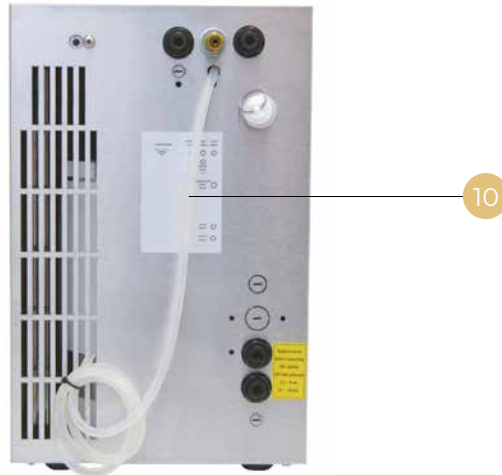

Electrical connection



- Check that the frequency and supply voltage of the product indicated on the type plate correspond to the values of the supply network.
- The power cord must be laid so that it is not crushed, pinched, stretched, stepped on, bent, wet or obstructed.

To ensure correct electrical connection, proceed as follows:

- Connect the supplied power cord to the IEC socket 13;
- Connect the power cord to the mains;
- If available and switched on, switch off the boiler by turning the boiler switch 12 to the 0 position;
- Switch on the product by pressing the main switch 11;
- Dispense carbonated water from the tap to release any air in the circuit and allow the pump to fill the carbonator with water;
- After about 1-2 minutes, the carbon dioxide pump will stop.

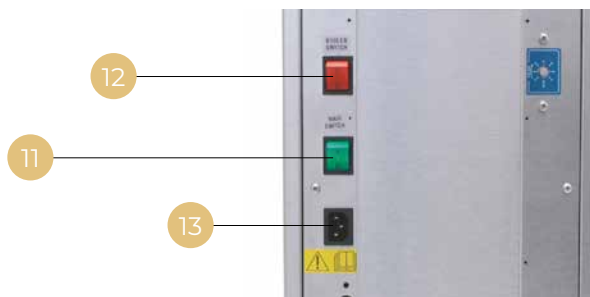

KATARA WITH UNDER-TABLE BOX

CO₂ connection (mod. FIZZ)



- Explosion hazard: The CO₂ cylinder must be kept away from heat sources.
- Do not attempt to manipulate or unscrew the safety valve during the venting process.
- After loosening the ring, check that the valve is properly closed and that there are no leaks.

Follow the instructions to connect the CO₂ cylinder:

- Connect the CO₂ inlet hose to the cylinder pressure regulator **14**;
- Connect the CO₂ supply hose to the CO₂ inlet connection **15**;
- Securely fasten the CO₂ cylinder in an upright position to the supplied bracket;
- Attach the pressure regulator to the CO₂ cylinder **16**;



KATARA WITH UNDER-TABLE BOX

- Adjust the CO₂ inlet pressure by adjusting the pressure regulator until the pressure is between 3.5 and 4 bar;
- Switch on the product by setting the main switch 11 to position I;
- Briefly dispense carbonated water to charge the tank;
- Open the top cover: loosen the screw(s) 3 and remove the cover;
- Vent the air from the water circuit: pull the ring on the safety valve 18 until water comes out;
- Check that the safety valve 18 has no leaks;
- Close the top cover of the machine again.

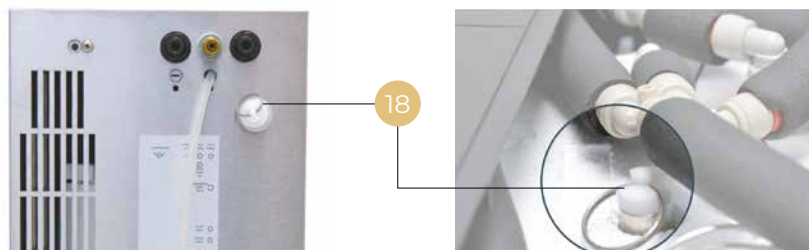
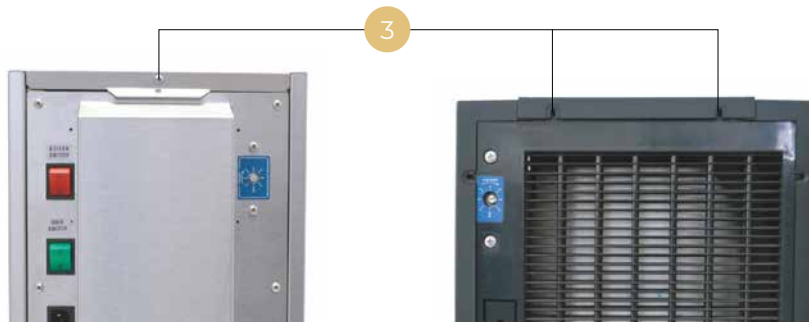

4.6 Cold water temperature control



- Lowering the temperature too much can cause the product inside to freeze.

To adjust the cold water temperature, proceed as follows:

- Turn the thermostat screw clockwise to lower the temperature;
- Turn the thermostat screw **19** counterclockwise to increase the temperature.

If the hydraulic circuit is frozen, switch off the device for at least 12 hours. Increase the temperature before switching it back on again.

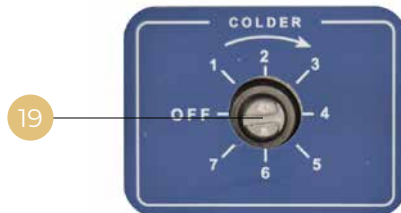

4.7 Regulating the flow of carbonated water

To adjust the flow of water, proceed as follows:

- Adjust the flow using the compensator **20**: Turn it clockwise to increase the flow and counterclockwise to decrease it. Too rapid a flow can impair the quality of the carbonated water.





4.8 Hot water temperature control (mod. HOT)



- Risk of burns from water or steam:
Hot water reaches a temperature of 96 °C (205 °F) +/-2 %.
- The hot water set point is factory set to 95 °C (203 °F) (mod. HOT). As the evaporation point of hot water can vary depending on the altitude of the installation site, it is necessary to lower the set point of the hot water thermostat if you notice steam coming out of the spout without hot water being supplied. Please contact be.pure customer service for further information.
- To ensure proper functioning and prevent damage to the system, you should descale the product regularly.
- We recommend descaling the product at least every 3 months using a special descaling agent suitable for plastics and light metal alloys, and rinsing it thoroughly.

To adjust the hot water temperature, proceed as follows:

- Turn the thermostat screw  counterclockwise to lower the temperature;
- Turn the thermostat screw  clockwise to increase the temperature.

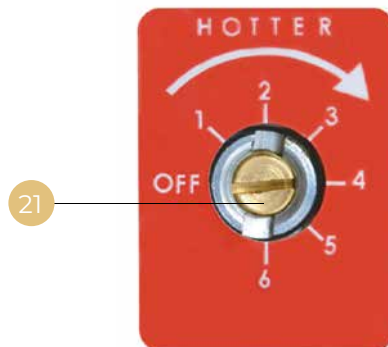

4.9 Replacing the CO₂ bottle



- Explosion hazard:
The CO₂ cylinder must be kept away from heat sources.

To replace the CO₂ cylinder, proceed as follows:

- If the cylinder is attached to a bracket, pull it out carefully;
- Disconnect the cylinder;
- Attach the new CO₂ cylinder to the pressure regulator;
- If necessary, attach the cylinder to the predefined bracket;
- Adjust the CO₂ inlet pressure by adjusting the pressure regulator until the pressure is between 3.5 and 4 bar;
- Briefly dispense carbonated water to charge the tank.



be.pure

Billing address:

Große Sperlgasse 8/2/34 · 1020 Vienna · Austria
www.bepure-water.com · office@bepure-water.com